

# SPECIFICATIONS

## TW030WA09/10 30 mm textile tweeter, 4/8 ohm

TW030WA09 and TW030WA10 are tweeters designed for applications requiring the highest level of performance, with extended and linear high frequency response and best consistency.

### Innovation

Tweeters used to feature a separate rear chamber in order to obtain low resonance frequency. Not any longer. By designing the internal parts to accommodate new larger internal volumes, the TW030WA09/10 offer an unusually low resonance frequency.

### FEATURES

- 30 mm design with controlled off-axis and power response, high power handling, and low resonance frequency
- Internal volumes for low resonance frequency and distortion
- Precision-coated textile diaphragm for improved consistency and high-frequency extension
- Optimized dome shape for ultra high frequency cutoff
- Vented voice coil former for reduced distortion and compression
- Copper-clad aluminium voice coil wire offering lower moving mass for improved efficiency and transient response
- Build-in cavities under dome/edge to equalize pressure for lower distortion and lower resonance frequency
- Flexible lead wires for higher power handling and larger excursion
- Gold plated terminals to prevent oxidation and ensure long-term reliable connection
- Delivered with foam gasket attached for hassle-free mounting and secure cabinet sealing



### NOMINAL SPECIFICATIONS

Notes	Parameter	Value		Unit
		TW030WA09	TW030WA10	
	Nominal size	30	30	[mm]
	Nominal impedance	4	8	[ohm]
	Recommended frequency range	2 - 25	2 - 25	[kHz]
1, 4	Sensitivity, 2.83V/1m (average SPL in range 5 - 20 kHz)	93	91	[dB]
2	Power handling, short term, IEC 268-5, 2.5 kHz@12dB/oct.	750	750	[W]
2	Power handling, long term, IEC 268-5, 2.5 kHz@12dB/oct.	200	200	[W]
2	Power handling, continuous, IEC 268-5, 2.5 kHz@12dB/oct.	60	60	[W]
	Effective radiating area, $S_d$	11.5	11.5	[cm <sup>2</sup> ]
3, 4, 6	Resonance frequency (free air, no baffle), $F_s$	725	750	[kHz]
	Moving mass, incl. air (free air, no baffle), $M_{ms}$	0.45	0.42	[g]
3	Force factor, $B_{xl}$	2.0	2.4	[N/A]
3, 4, 6	Suspension compliance, $C_{ms}$	0.11	0.11	[mm/N]
3, 4, 6	Equivalent air volume, $V_{as}$	20	20	[mlit.]
3, 4, 6	Mechanical resistance, $R_{ms}$	0.25	0.25	[Ns/m]
3, 4, 6	Mechanical Q, $Q_{ms}$	8.1	7.8	[-]
3, 4, 6	Electrical Q, $Q_{es}$	1.74	2.17	[-]
3, 4, 6	Total Q, $Q_{ts}$	1.43	1.70	[-]
4	Voice coil resistance, $R_{DC}$	3.4	6.3	[ohm]
5	Voice coil inductance, $L_e$ (measured at 1 kHz)	38	73	[μH]
	Voice coil inside diameter	30	30	[mm]
	Voice coil winding height	1.7	1.7	[mm]
	Air gap height	2.5	2.5	[mm]
	Theoretical linear motor stroke, $X_{max}$	±0.4	±0.4	[mm]
	Magnet weight	170	170	[g]
	Total unit net weight excl. packaging	400	400	[g]
3, 4, 5	$K_{rm}$			[mohm]
3, 4, 5	$E_{rm}$			[-]
3, 4, 5	$K_{xm}$			[mH]
3, 4, 5	$E_{xm}$			[-]

Note 1 Measured in infinite baffle.

Note 2 Tested in free air (no cabinet, no baffle).

Note 3 Measured using a semi-constant current source, nominal level 2 mA.

Note 4 Measured at 25 deg. C

Note 5 It is generally a rough simplification to assume that loudspeaker transducer voice coils exhibit the characteristics of an inductor. Instead it is a far more accurate approach to use the more advanced model often referred to as the "Wright empirical model", also used in LEAP-4 as the TSL model ([www.linearx.com](http://www.linearx.com)), involving parameters  $K_{rm}$ ,  $E_{rm}$ ,  $K_{xm}$ , and  $E_{xm}$ . This more accurate transducer model is described in a technical paper [here at our web site](#).

Note 6 Measured before burn in. The unit is not burned in before shipping.

# SPECIFICATIONS

## TW030WA09/10 30 mm textile tweeter, 4/8 ohm

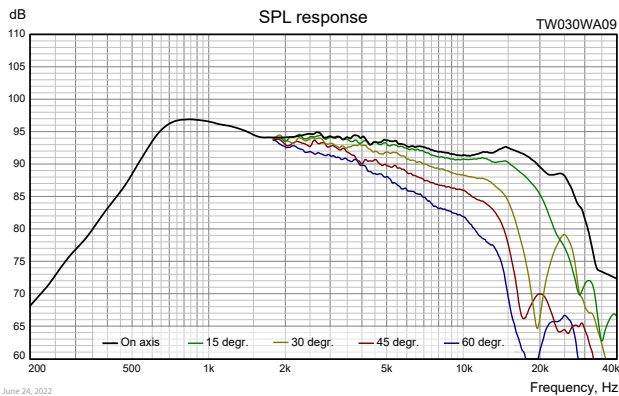

[Download TW030WA09 on-axis SPL response as .txt file](#)

**Measuring conditions, SPL**  
 Driver mounting: Flush in infinite baffle, back side open (no cabinet)  
 Microphone distance: 1.0 m  
 Input signal: 2.83 VRMS stepped sine wave  
 Smoothing: 1/6 oct.

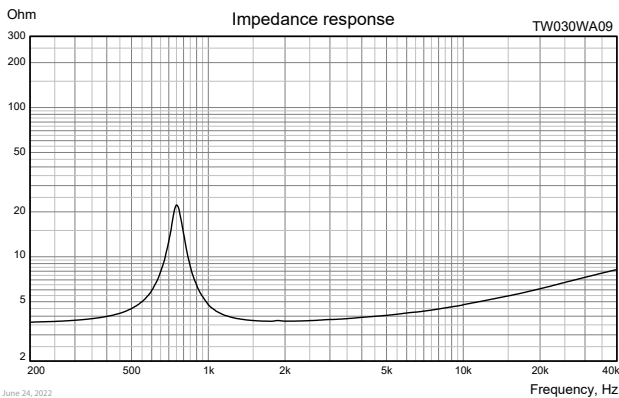

[Download TW030WA09 Impedance response as .txt file](#)

**Measuring conditions, impedance**  
 Driver mounting: Free air, no baffle, back side open (no cabinet)  
 Input signal: Stepped sine wave, semi-current-drive, nominal current 2 mA  
 Smoothing: None

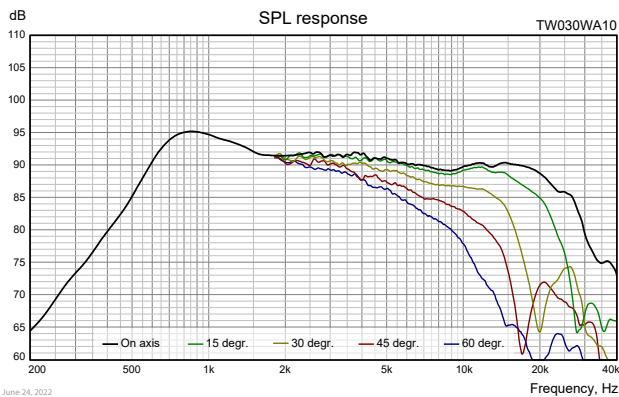

[Download TW030WA10 on-axis SPL response as .txt file](#)

**Measuring conditions, SPL**  
 Driver mounting: Flush in infinite baffle, back side open (no cabinet)  
 Microphone distance: 1.0 m  
 Input signal: 2.83 VRMS stepped sine wave  
 Smoothing: 1/6 oct.

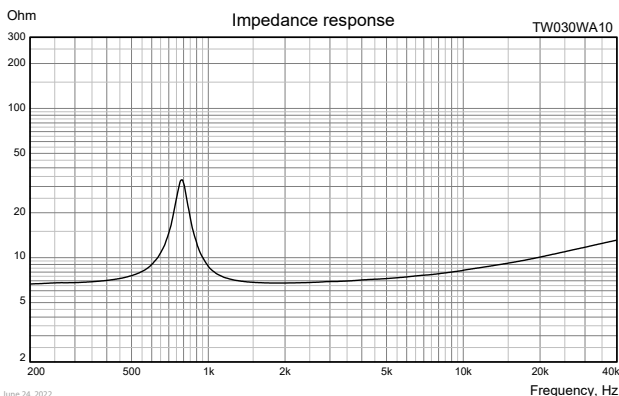

[Download TW030WA10 Impedance response as .txt file](#)

**Measuring conditions, impedance**  
 Driver mounting: Free air, no baffle, back side open (no cabinet)  
 Input signal: Stepped sine wave, semi-current-drive, nominal current 2 mA  
 Smoothing: None

# SPECIFICATIONS



## TW030WA09/10 30 mm textile tweeter, 4/8 ohm

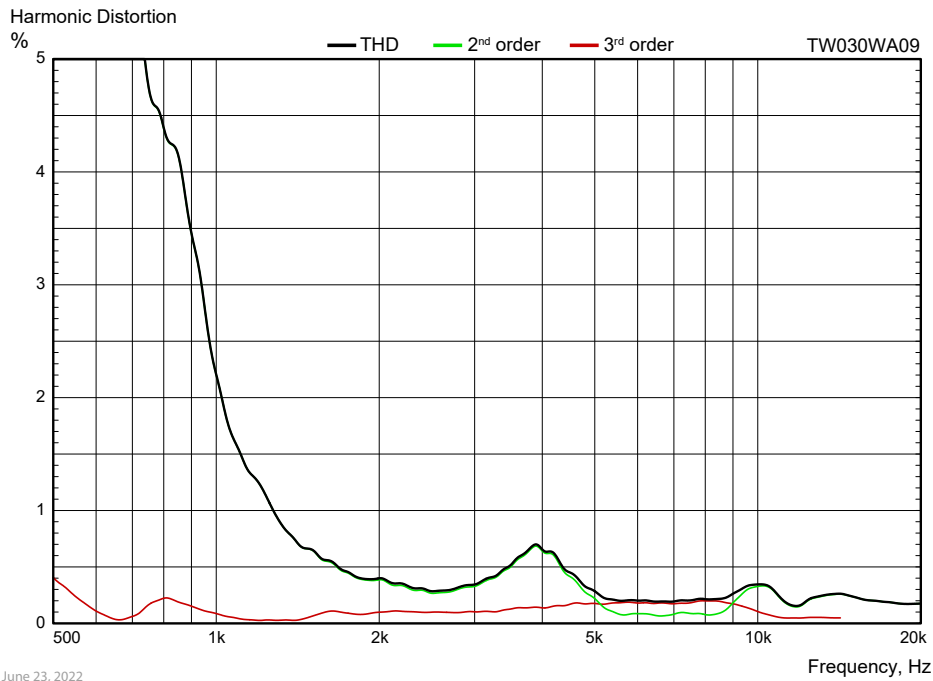

Measuring conditions, Harmonic Distortion

Driver mounting: Infinite baffle

Microphone distance: 0.5 m

Input signal: Stepped sine wave, 2.0 VRMS (TW030WA09) / 2.83 VRMS (TW030WA10)

Smoothing: 1/6 oct.

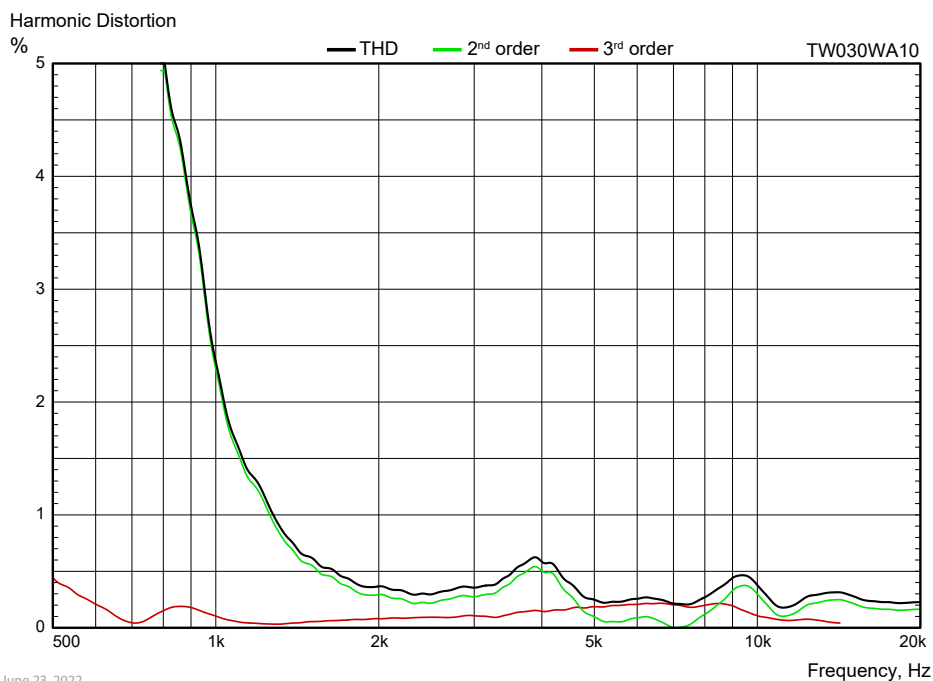

# SPECIFICATIONS

**TW030WA09/10 30 mm textile tweeter, 4/8 ohm**

### OUTLINE DRAWING (nominal dimensions)

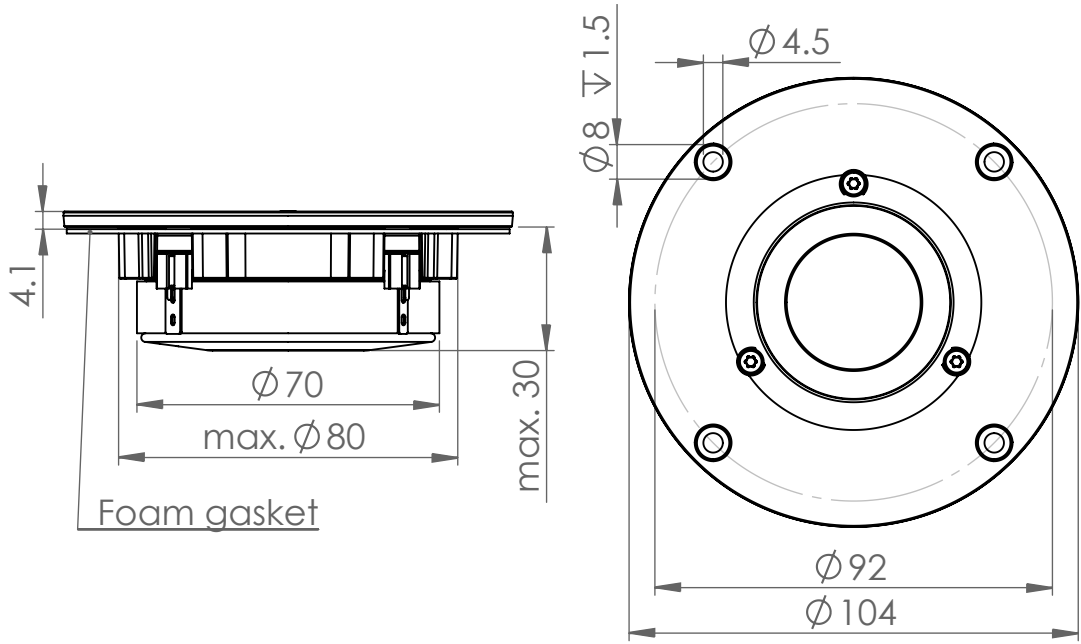

### CONNECTIONS

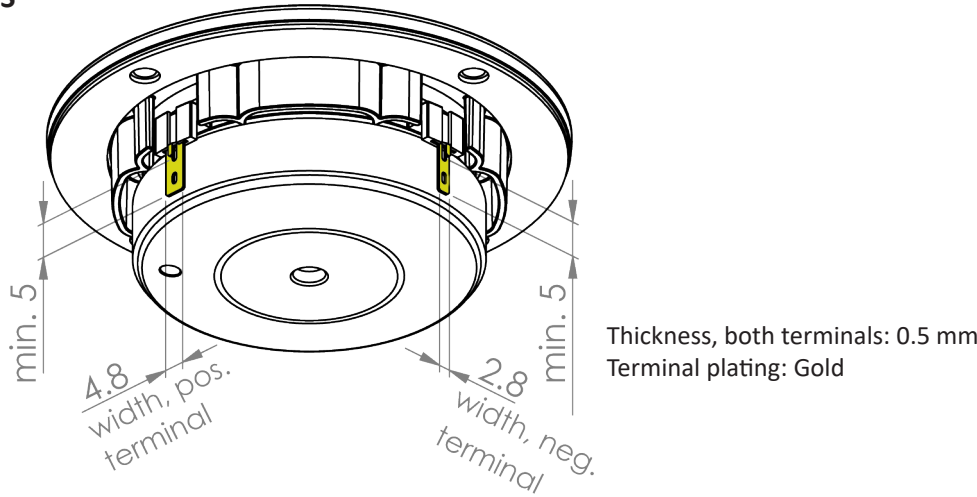

### PACKAGING AND ORDERING INFORMATION

Part no. TW030WA09-01	4 ohm, individual packaging (one piece per box)
Part no. TW030WA09-02	4 ohm, bulk packaging
Part no. TW030WA10-01	8 ohm, individual packaging (one piece per box)
Part no. TW030WA10-02	8 ohm, bulk packaging

Latest update: Jun. 24, 2022