

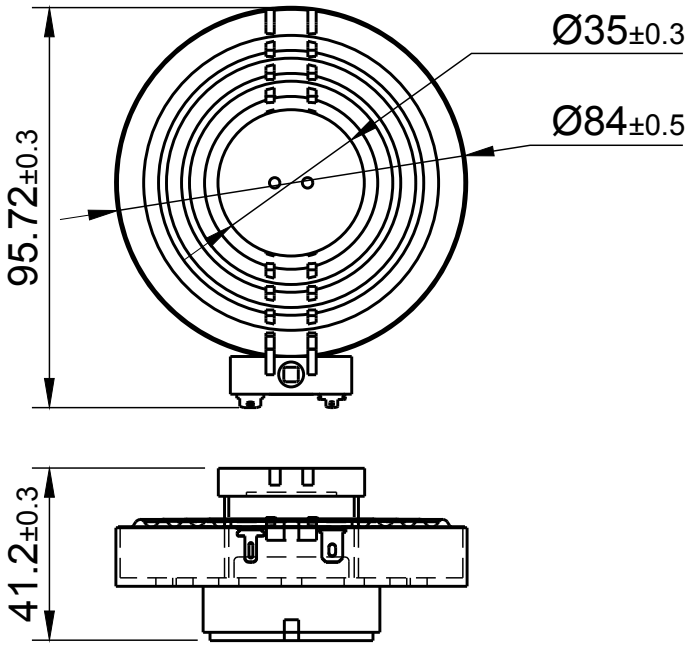

IMS™ Dual Suspension Vented Bass 32mm Interchangeable Hardware  
Mount Exciter 40W 4 Ohm  
EX32VBDS-4



Note: All dimensions in mm.

**FEATURES**

- Exclusive IMS Interchangeable mount allows you to A/B test different exciters
- Rare-earth neodymium motor and a proprietary two-layer voice coil
- 40 watt RMS power handling

**APPLICATIONS**

- Electronic gaming machines
- Advertising signage
- Point-of-purchase displays
- Multimedia exhibits
- Commercial distributed audio
- Kiosks
- Automotive audio

**PARAMETERS**

Impedance	4 ohms
Re	3.6 ohms
Le	0.43 @ 10kHz
Fs	85.4 Hz
Qms	N/A
Qes	N/A
Qts	0.75
Mms	N/A
Cms	N/A
Sd	N/A
Vd	N/A
Bl	N/A
Vas	N/A
Xmax	N/A
VC Diameter	32 mm
SPL	N/A
RMS Power Handling	40 watts
Useable Freq Response	N/A

**IMPEDANCE/PHASE**

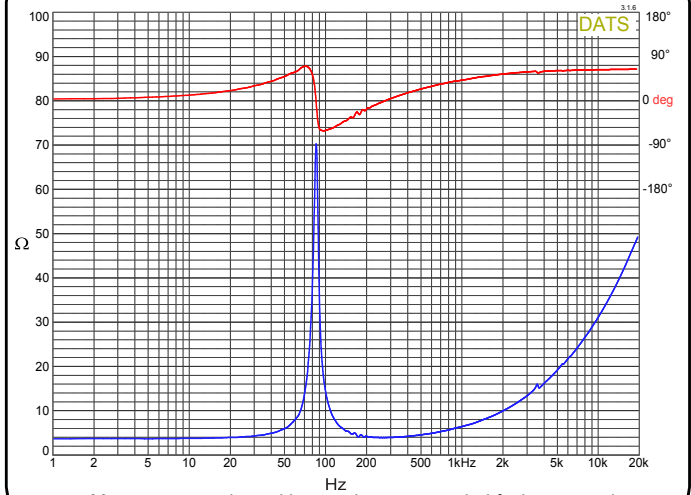

**FREQUENCY RESPONSE**

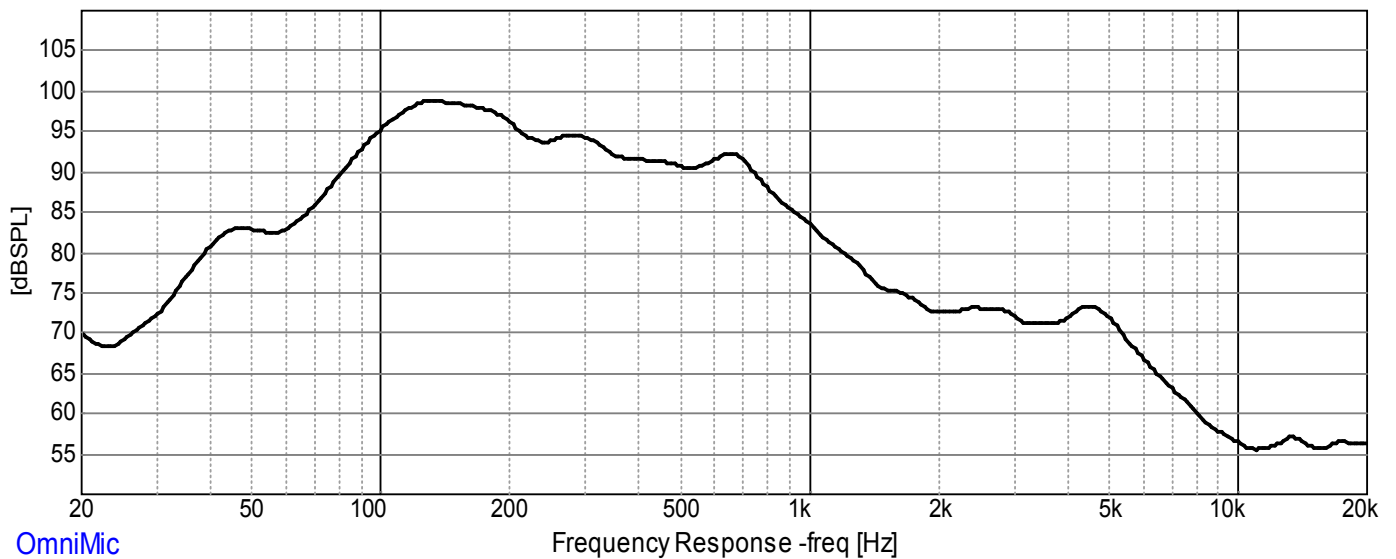

1/3rd octave smoothing - measurement taken with transducer adhered off-center on a 12" x 12" x 1/2" foam core board in an infinite baffle setup.

Note: This information is for comparison purposes only, the actual frequency response will depend on many factors of which the diaphragm being the greatest contributor.