

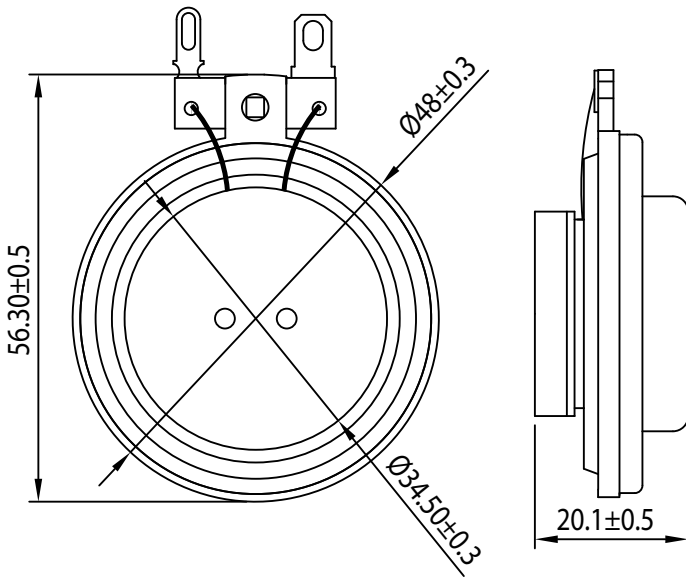

IMS™ Coin Type 25mm Interchangeable Hardware Mount Exciter 10W 4 Ohm
EX25CT2-4



PARAMETERS

Impedance	4 ohms
Re	3.6 ohms
Le	0.07 mH @ 1 kHz
Fs	137 Hz
Qms	N/A
Qes	N/A
Qts	2.48
Mms	N/A
Cms	N/A
Sd	N/A
Vd	N/A
BL	1.54 Tm
Vas	N/A
Xmax	N/A
VC Diameter	25 mm
SPL	N/A
RMS Power Handling	10 watts
Usable Frequency Range (Hz)	N/A

FEATURES

- Small size; just under 2" diameter, about 9/16" high
- Exclusive IMS™ Interchangeable mount allows you to A/B test different exciters
- Rare-earth neodymium motor and a proprietary voice coil
- 1" voice coil for 10 watt RMS power handling

APPLICATIONS

- Electronic gaming machines
- Advertising signage
- Point-of-purchase displays
- Multimedia exhibits
- Commercial distributed audio
- Kiosks
- Automotive audio

IMPEDANCE/PHASE

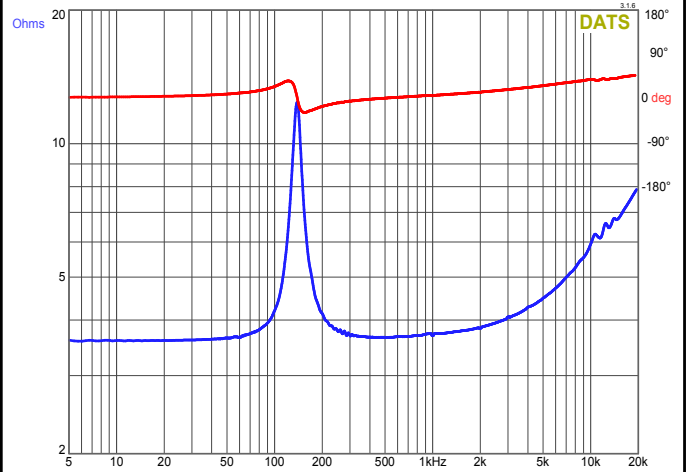

Measurement taken with transducer uncoupled facing upward.

FREQUENCY RESPONSE

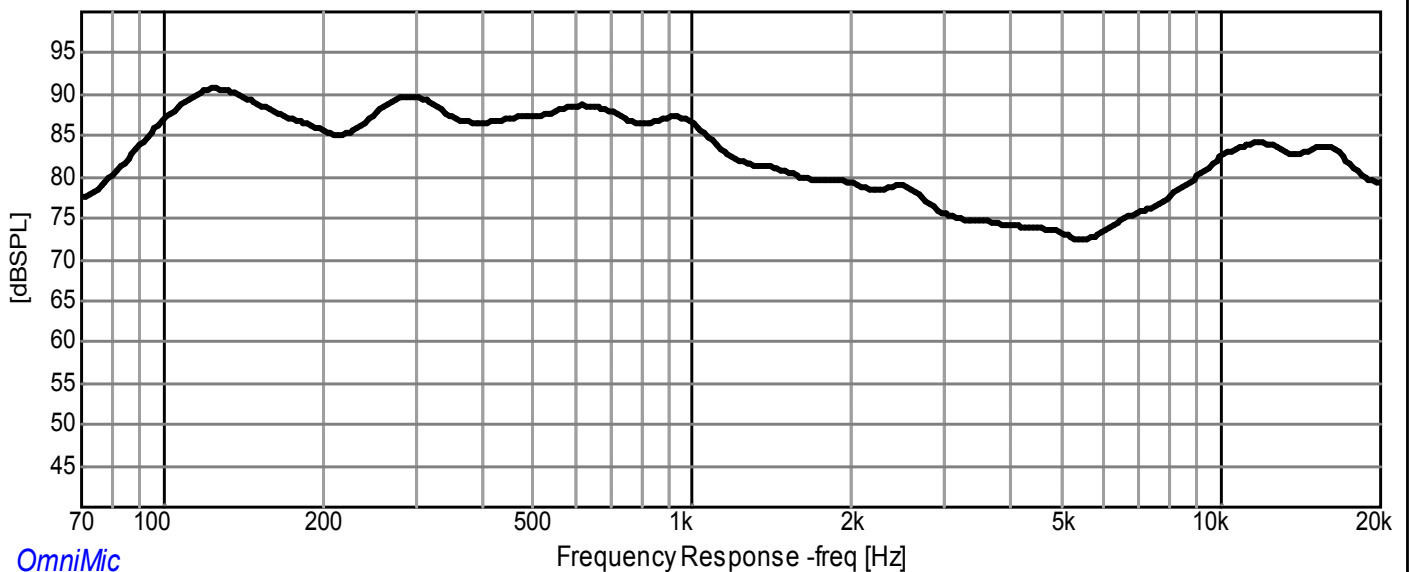

OmniMic

1/3rd octave smoothing - measurement taken with transducer adhered off-center on a 12" x 12" x 1/2" foam core board in an infinite baffle setup.

Note: This information is for comparison purposes only, the actual frequency response will depend on many factors of which the diaphragm being the greatest contributor.