

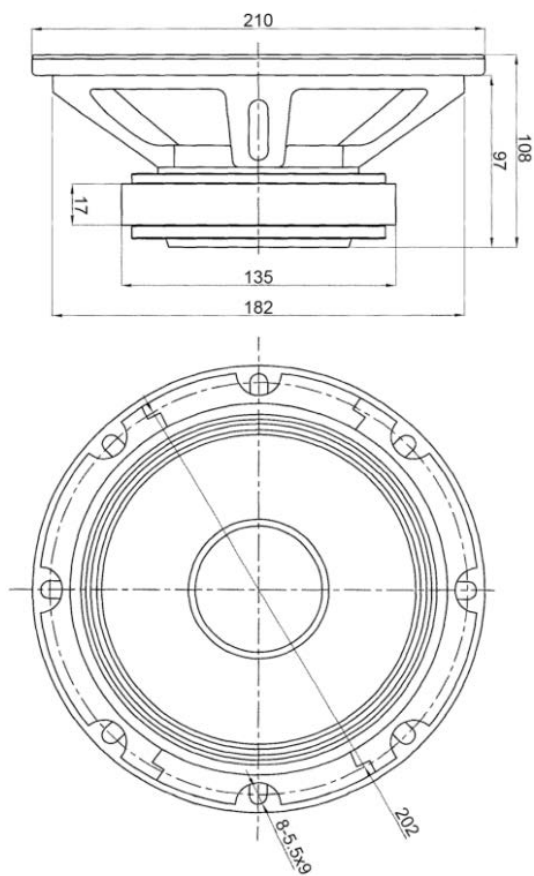

PA200-8 8" PA Woofer 8 Ohm

PA200-8



PARAMETERS

Impedance	8 ohms
Re	6.2 ohms
Le	1.09 mH
Fs	55.2 Hz
Qms	6.17
Qes	0.51
Qts	0.48
Mms	20.5g
Cms	0.4 mm/N
Sd	210.4 cm ²
Vd	0.631 cm ³
BL	9.28 Tm
Vas	26.6 liters
Xmax	3.0 mm
VC Diameter	50 mm
SPL	92.4 dB 2.83V/1m
RMS Power Handling	250 watts
Usable Frequency Range (Hz)	70 - 9,000 Hz

FEATURES

- Strong, low-mass carbon fiber impregnated paper cone
- Low distortion motor system with copper cap
- Vented pole piece and voice coil gap improve thermal management
- Black motor parts and black polyimide voice coil former dissipate heat
- Bumped back plate for unrestricted excursion

IMPEDANCE/PHASE



FREQUENCY RESPONSE

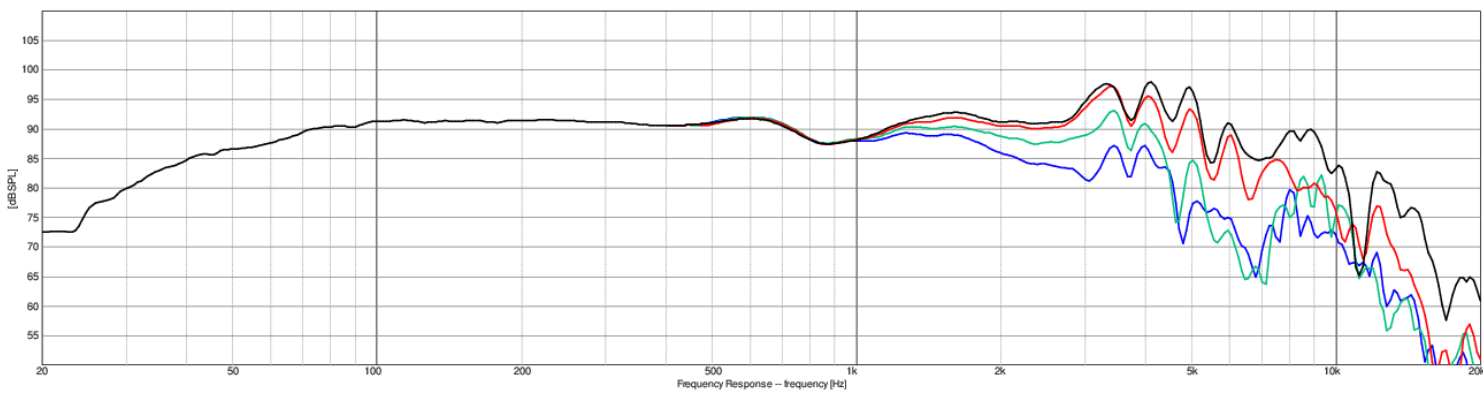

Note: 1/24th octave smoothing - nearfield response included in graph below 450 Hz.

Black = 0°
Red = 15°
Green = 30°
Blue = 45°