

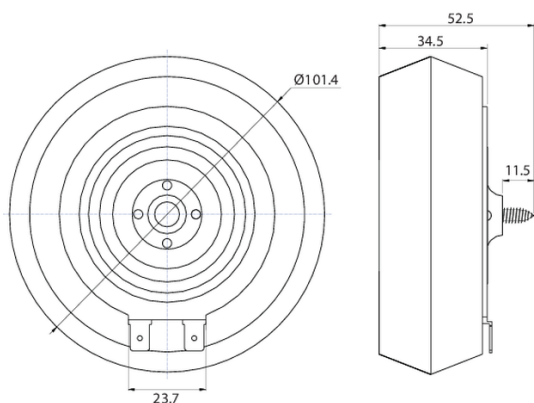

HDN-8 Weatherproof Sound Exciter Transducer

HDN-8



FEATURES

- Rugged plastic housing with black matte finish
- Coarse-threaded mounting stud for single-point mounting into almost any material
- Hermetically-sealed design for installation in wet or humid environments

APPLICATIONS

- Invisible home theater and multi-room audio
- Electronic gaming machines
- Advertising signage
- Point-of-purchase displays
- Multimedia exhibits
- Commercial distributed audio
- Kiosks
- Automotive audio
- Bathroom tubs and showers

PARAMETERS

Impedance	8 ohms
Re	7.46 ohms
Le	0.86 mH @ 1 kHz
Fs	695 Hz
Qms	N/A
Qes	N/A
Qts	1.52
Mms	38.2 g
Cms	N/A
Sd	N/A
Vd	N/A
BL	18.2 Tm
Vas	N/A
Xmax	N/A
VC Diameter	50 mm
SPL	N/A
RMS Power Handling	50 watts
Usable Frequency Range (Hz)	40 - 15,000 Hz

IMPEDANCE/PHASE

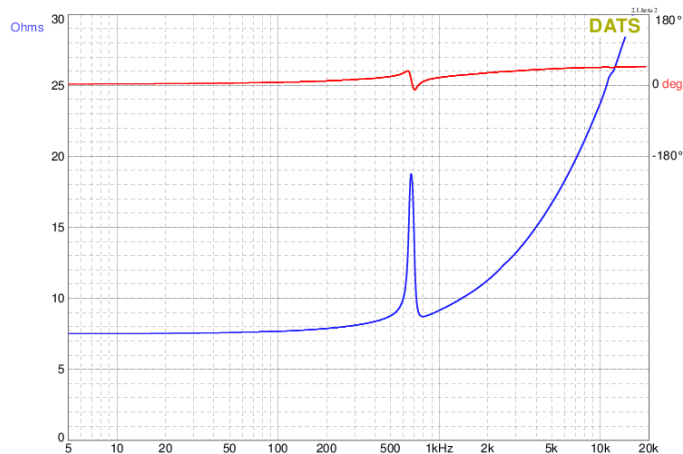

Measurement taken with transducer uncoupled facing upward.

FREQUENCY RESPONSE

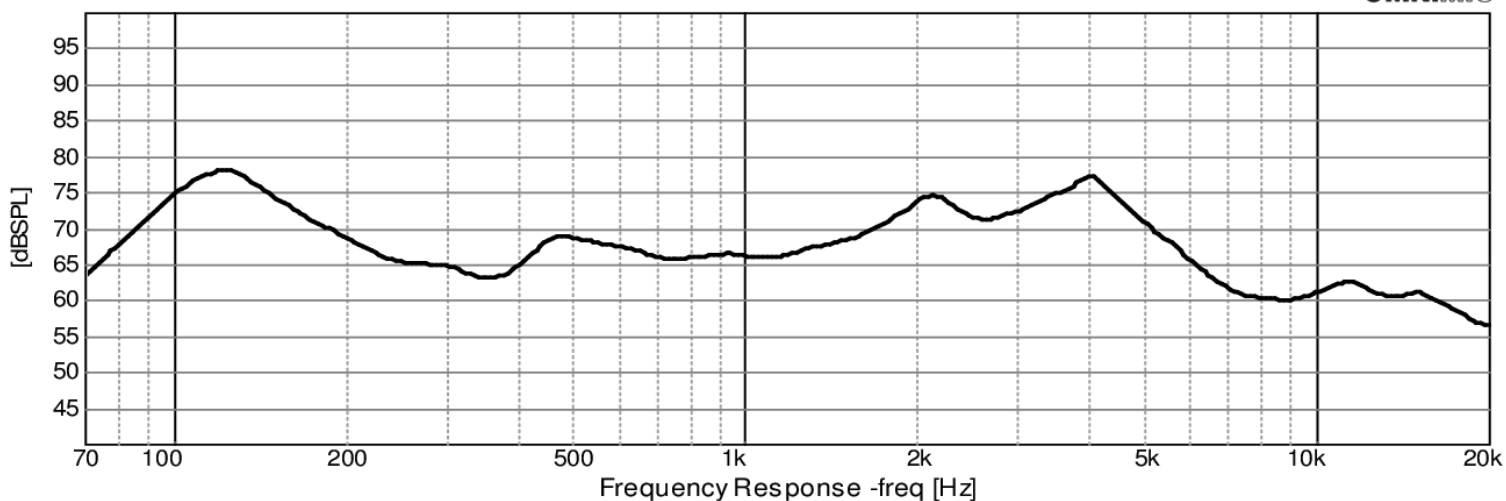

OmniMic

rd

1/3 octave smoothing - measurement taken with transducer adhered off-center
on a 12" x 12" x 1/2" foam core board in an infinite baffle setup.

Note: This information is for comparison purposes only, the actual frequency response will depend on many factors of which the diaphragm being the greatest contributor.