

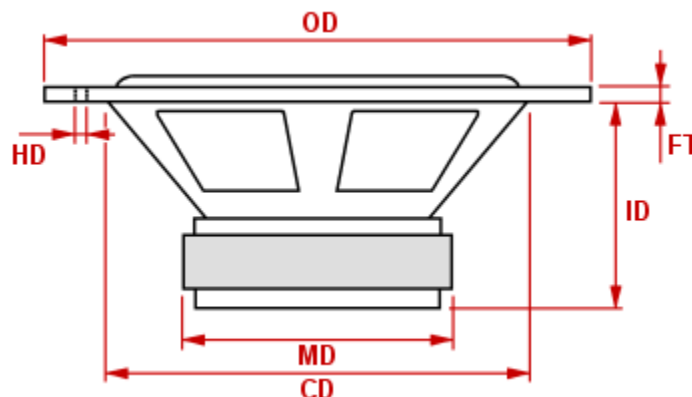

vifa

MG10MD09-08

Nominal impedance [ohm]	8
Voice coil resistance [ohm]	5.5
Nominal power [W]	-
Short term max power [W]	-
Long term max power [W]	-
Operating power [W]	-
Sensitivity [dB]	86
Frequency range [kHz]	0.1-15
Free air resonance [Hz]	81
Voice coil diameter [mm]	20
Voice coil height [mm]	5.1
Air gap height [mm]	3.8
Voice coil inductance [mH]	0.33
Eff. diaphragm Area [cm ²]	38
Moving mass [g]	3.2
Magnet weight [g]/[oz]	210/7.4
Force factor [BI]	3.8
VAS [l]	2.5
Qms	3.40
Qes	0.60
Qts	0.51



OD:	104 mm	CD:	81 mm
FT:	4 mm	ID:	44.4 mm
MD:	60 mm	HD:	-

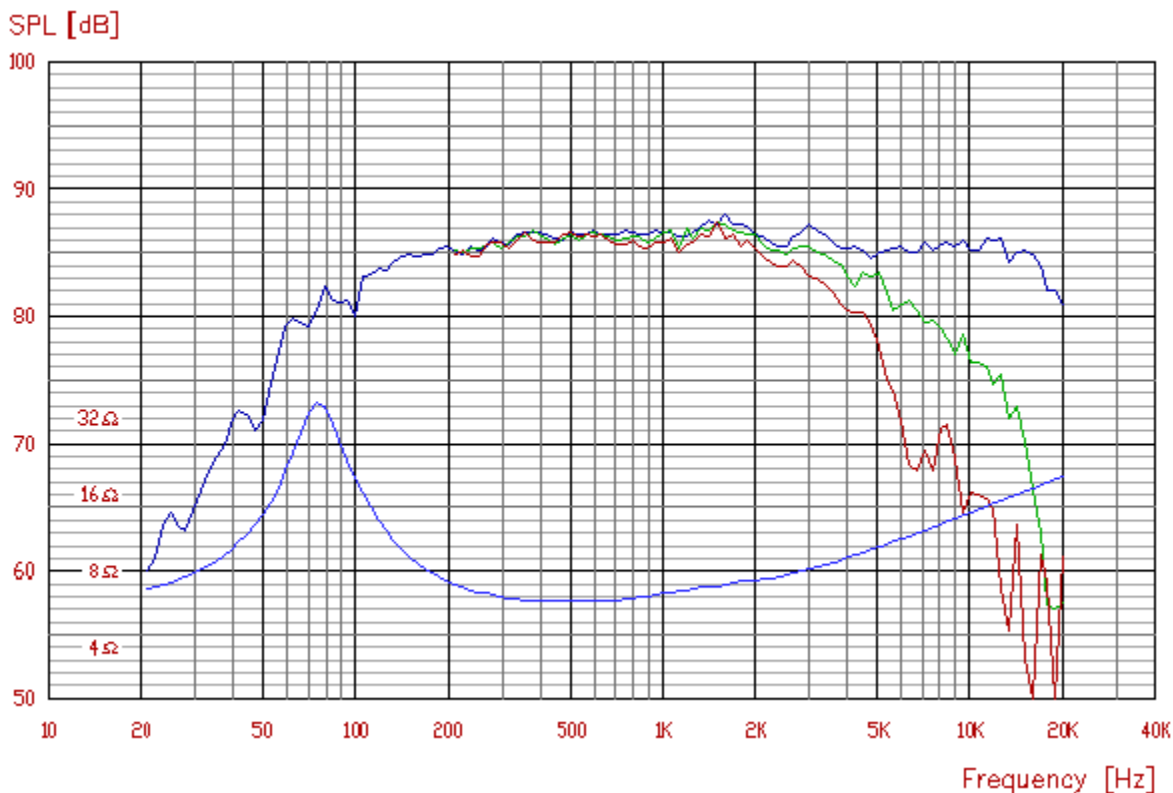

Frequency response: 2.83V / 1m