

## Illuminator 1" Tweeter



**Type Number:** D3004/662000

### Features:

The Illuminator tweeters continue on with the heritage of the renowned Revelator D29. The large-roll surround and textile dome diaphragm provide a flat frequency response to above 30KHz with outstanding off-axis dispersion.

The face plates are die cast in aluminum for a beautiful look with maximum mechanical stability.

Tymphany's unique AirCirc Magnet System - named for the way it optimizes air flow within the chamber – rearranges the traditional magnet structure from a single magnet to an open magnetic circuit comprised of six separate neodymium slugs. This, in combination with the chamber, results in the elimination of the reflections and resonances that compromise the performance of traditional motors. The D3004 gives engineers improved control over critical midrange performance, for superb vocal rendition and excellent imaging at all listening locations.

**Driver Highlights:** 1" soft dome, AirCirc Magnet System, Rubber painted aluminium die casted faceplate, Black



### Specs:

#### Electrical Data

Nominal impedance	Zn	4	ohm
Minimum impedance	Zmin	9	ohm
Maximum impedance	Zo	18.6	ohm
DC resistance	Re	3	ohm
Voice coil inductance	Le	0.03	mH

#### T-S Parameters

Resonance Frequency	fs	500	Hz
Mechanical Q factor	Qms	--	
Electrical Q factor	Qes	--	
Total Q factor	Qts	--	
Force factor	Bl	2.3	Tm
Mechanical resistance	Rms	--	Kg/s
Moving mass	Mms	0.35	g
Suspension compliance	Cms	0.29	mm/N
Effective cone diameter	D	--	cm
Effective piston area	Sd	7	cm <sup>2</sup>
Equivalent volume	Vas	--	ltrs
Sensitivity (2.83V/1m)		91.6	dB

#### Power handling

Long-term Max Power (IEC 18.3)	--	W
Short Term Max power (IEC 18.2)	--	W

#### Voice Coil and Magnet Parameters

Voice coil diameter	26	mm
Voice coil height	2.1	mm
Voice coil layers	2	
Height of the gap	2.5	mm
Flux density of gap	--	mWb
Total useful flux	--	mWb
Diameter of magnet	--	mm
Height of magnet	--	mm
Weight of magnet	0.3	Kg

Notes:  
IEC specs refer to IEC 60268-5 third edition.  
All Tymphany products are RoHS compliant.

## Frequency:

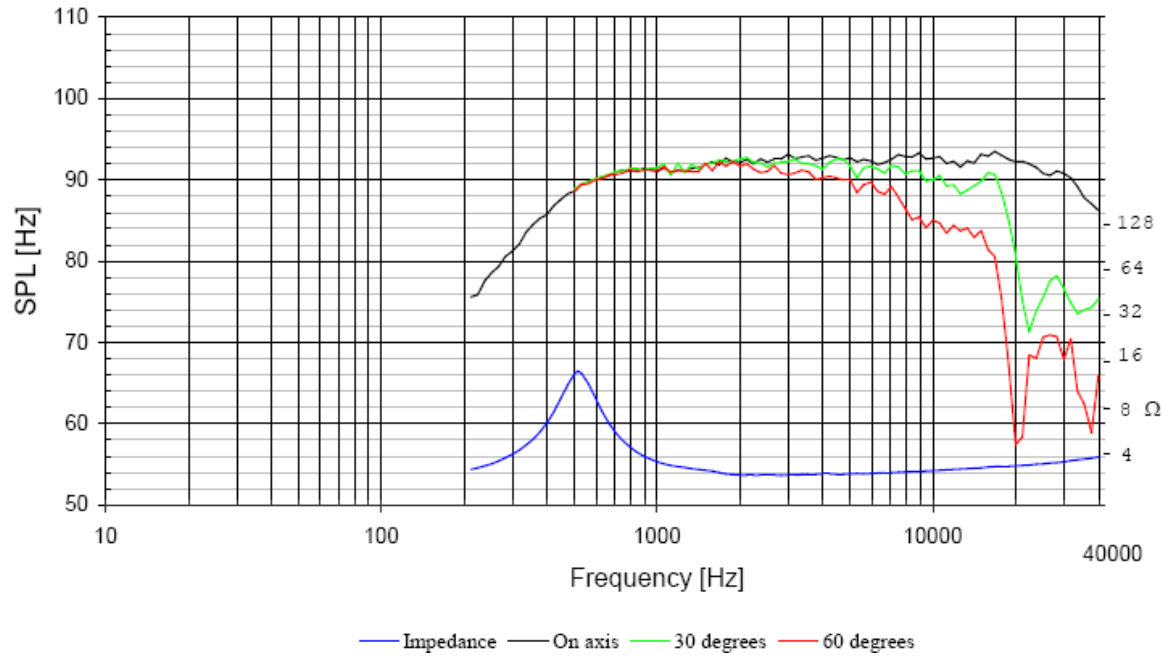

## Mechanical Dimensions:

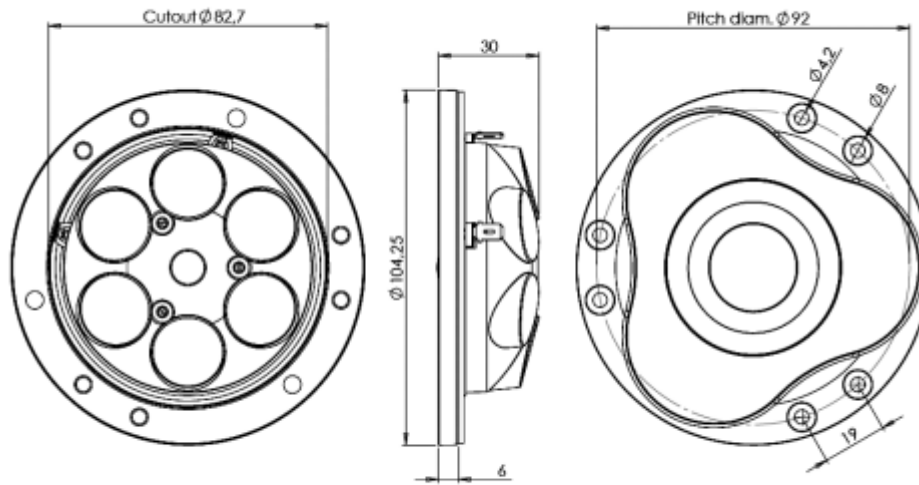

### Drawing Dimensions

- Outside Diameter
- Flange Thickness
- Magnet Diameter
- Cutout Diameter
- Interior Depth
- Hole Diameter
- Screw Circle Diameter